

# Z Table

## Single and Dual Surface

Tables

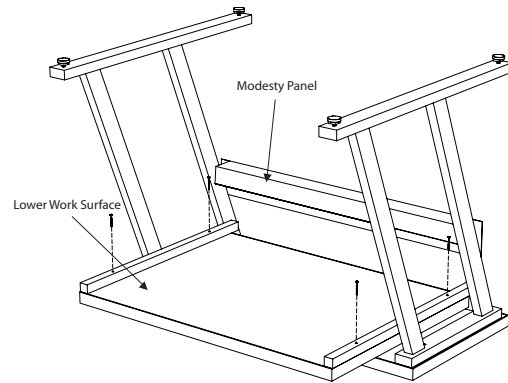
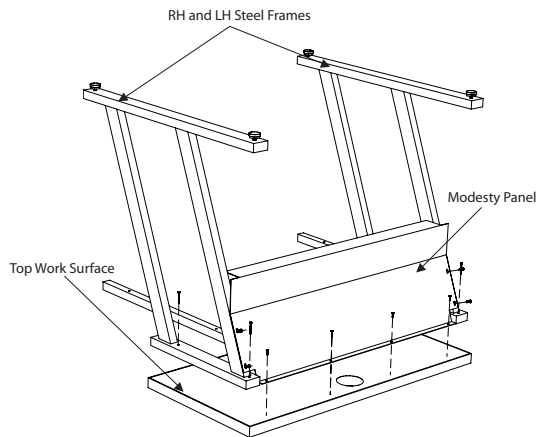
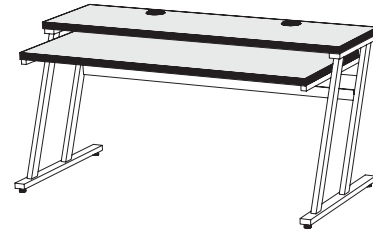
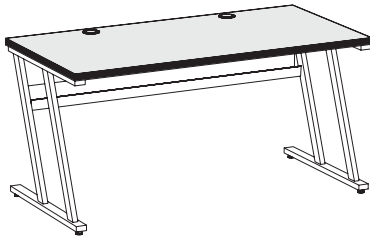

### Hardware Included:

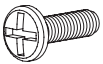

10-32 x 5/8"  
Machine Screws



#8 x 1" screws



#8 x 2" screws

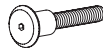

1/4-20 x 45mm  
connector bolts

### Tools Required:

- #2 Phillips Head Screwdriver
- 5mm Allen Wrench

### ATTENTION UNITS ARE ASSEMBLED UPSIDE DOWN

#### STEP 1: Attaching modesty panel

Align modesty panel to pilot holes in underside of longer and narrower top work surface and attach using #8 X 1" screws. Top work surface is longer and narrower in dual surface Z tables.

#### STEP 2: Attaching frames to upper table top

All Units: Slide RH and LH steel frames into alignment with oblong holes on each end of modesty panel and connect panel to frame using (4) 10-32 X 5/8" screws. All dual surface and under 60" single surface units: Align top rails of frames with underside of top work surface and attach using (2) #8 X 2" screws on each side.

#### STEP 3: Attaching work surface support bar

Dual surface units: Attach the 1" x 1" work surface support bar between the steel frames by bolting through each 1" x 1" frame member into the ends of the support bar using 1-3/4" (45mm) 1/4-20 connector bolts. Single surface units: Attach the 1" x 1" lower work surface support bar by bolting through each 1" x 2" frame member into the ends of the support bar using 2-3/4" (70mm) 1/4-20 connector bolts. Align frames with edges of worksurface and attach using (2) #8 x 2" screws through each 1" x 2" frame member.

#### STEP 4: Attaching lower table top (if working with a singular work surface Z Table skip to step 5)

Align shorter and wider lower work surface to rails along steel frames. NOTE: You will need to aid/hold the table top to the frames. Attach using (2) #8 X 2" screws per side. If support bar was installed, attach lower work surface to bar using #8 X 2" screws.

#### STEP 5: Completing assembly

Flip table over and install plastic grommets.

FOR UNITS 60" AND LONGER SEE STEP 3, FOR SHORTER UNITS PROCEED TO STEP 4.

instructions-ztable-230303

